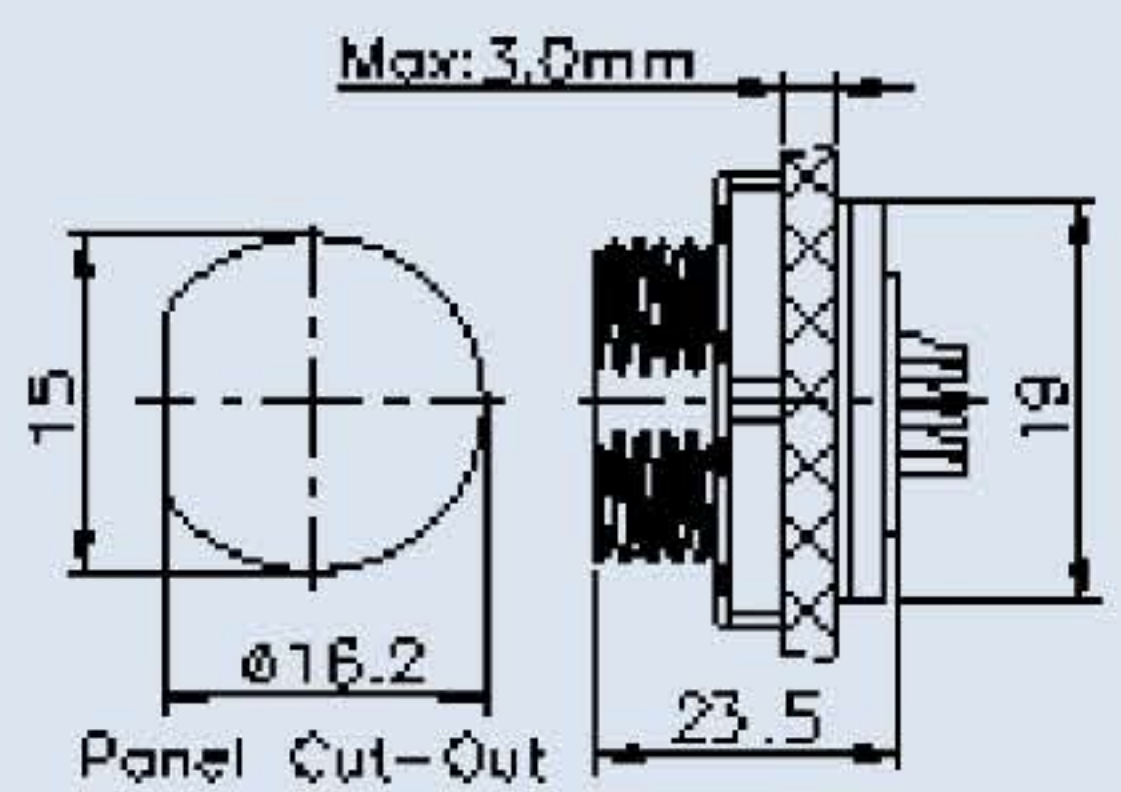
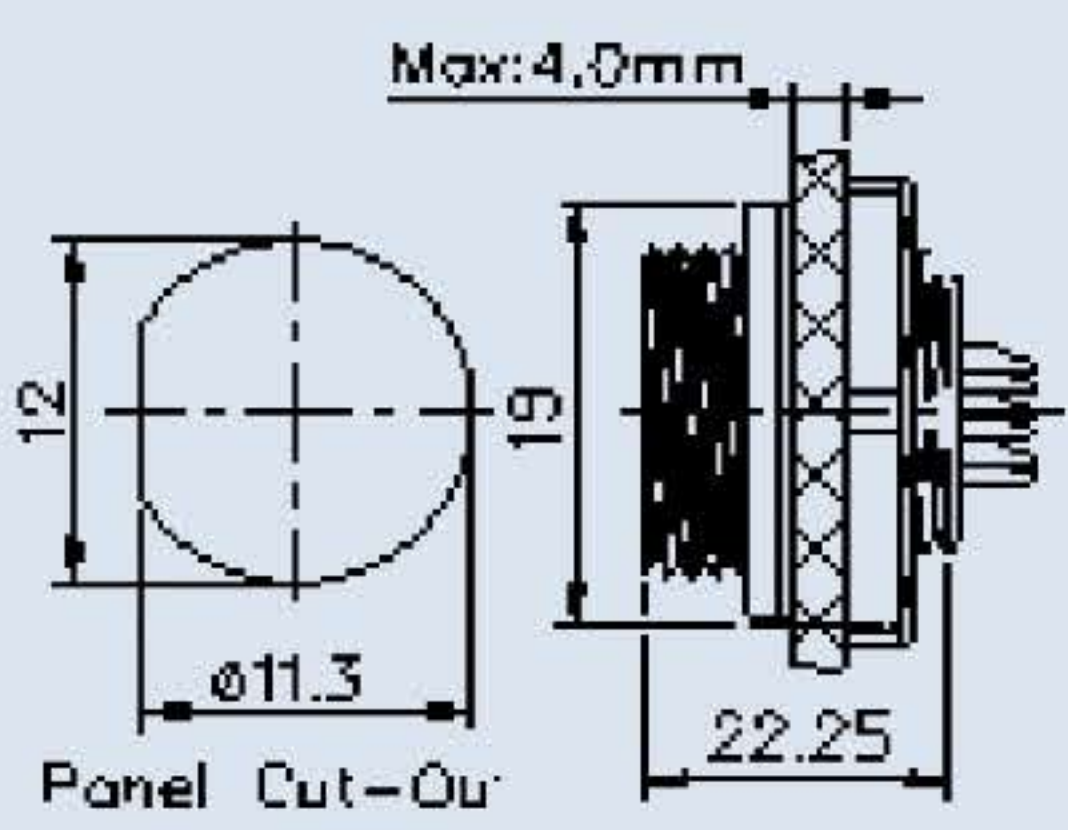
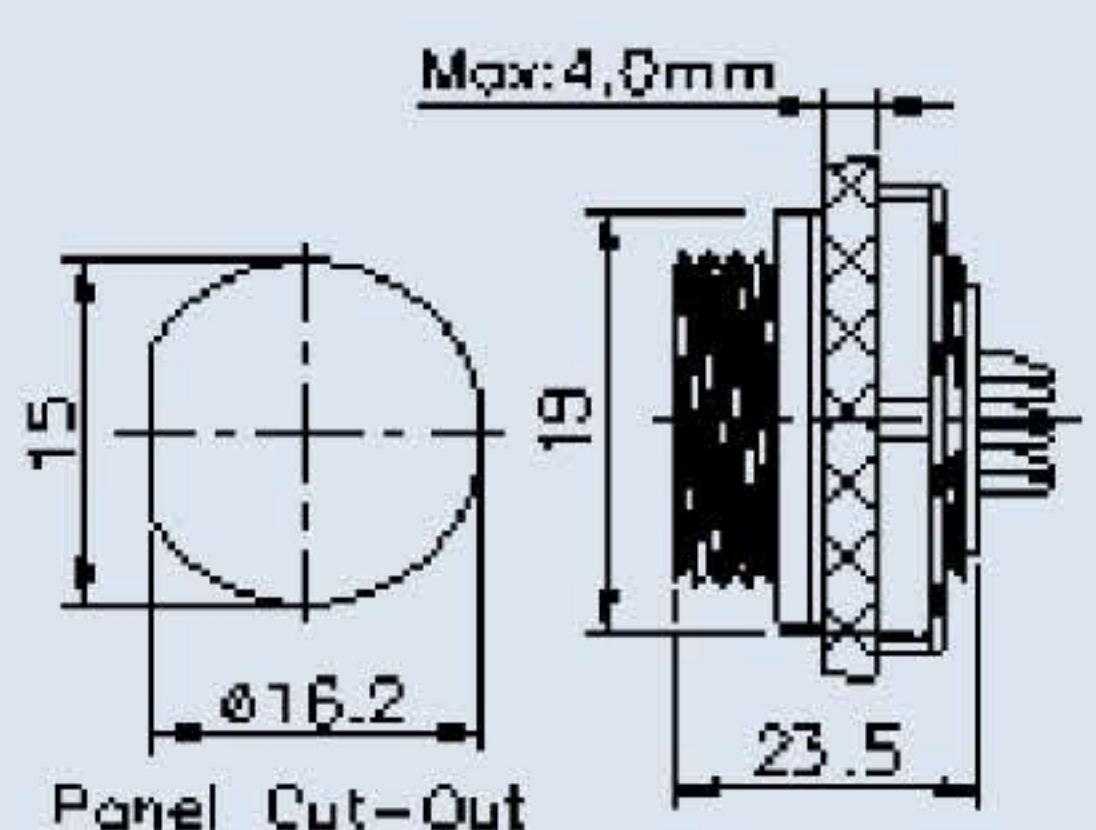

STANDARD Series ,Screw

Description	Front Panel Mount, Male Screw Type, Solder	Rear Panel Mount, Male Screw Type, Solder	Rear Panel Mount, Male Screw Type, Solder
Figure			

Drawing			
---------	---	--	---

Part Number	Contacts	Part Number	Contacts	Part Number	Contacts	Part Number
	2	M14BMF02	2	HYF-190A05-02	2	M16BMR02
	3	M14BMF03	3	HYF-190A05-03	3	M16BMR03
	4	M14BMF04	4	HYF-190A05-04	4	M16BMR04
	5	M14BMF05	5	HYF-190A05-05	5	M16BMR05
	6	M14BMF06	6	HYF-190A05-06	6	M16BMR06
	8	M14BMF08	8	HYF-190A05-08	8	M16BMR08
	9	M14BMF09				
	10	M14BMF10				
	2+5	M14BMF2+5				

Specifications							
Number of Contacts	2	3	4	5	6	8	9 10 2+5
Panel Thickness	MAX 3mm/4mm						
Environmental Protection	IP67						
Mechanical Life	500mating cycles						
Operating Temperature	- 45°C - 105°C						
DC Voltage Rating	500V				400V		300V
Rated Current (40°C)	15A			5A			